

VIVOIL OLEODINAMICA VIVOLO s.r.l.  
Società a Socio Unico  
www.vivoil.com  
BUDRIO (BOLOGNA) ITALY  
Tel +39 051.803689 Fax +39 051.800061

**XV1P/7.8 - Ø32 BH /D OUT - CI002**  
Z - Z - IN 3/8" BPS

Disegno: **7P3444003**  
Data - Emissione: 04/06/20

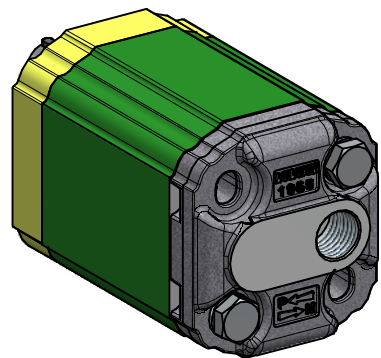
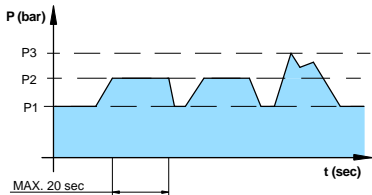
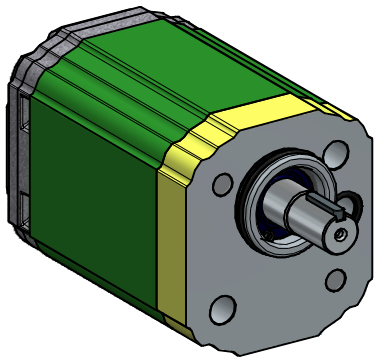

pressione limitata dalla coppia dell'albero - limited pressure by shaft torque

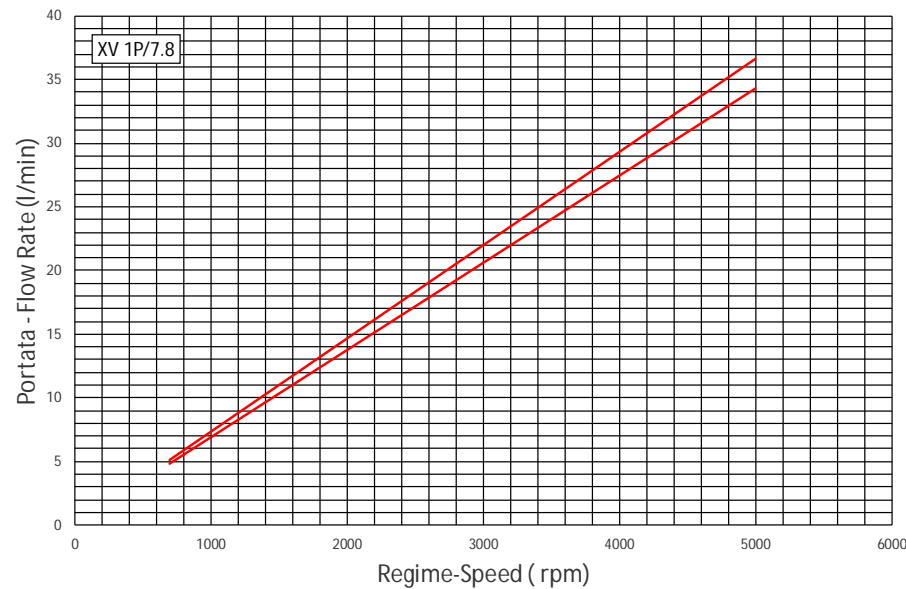
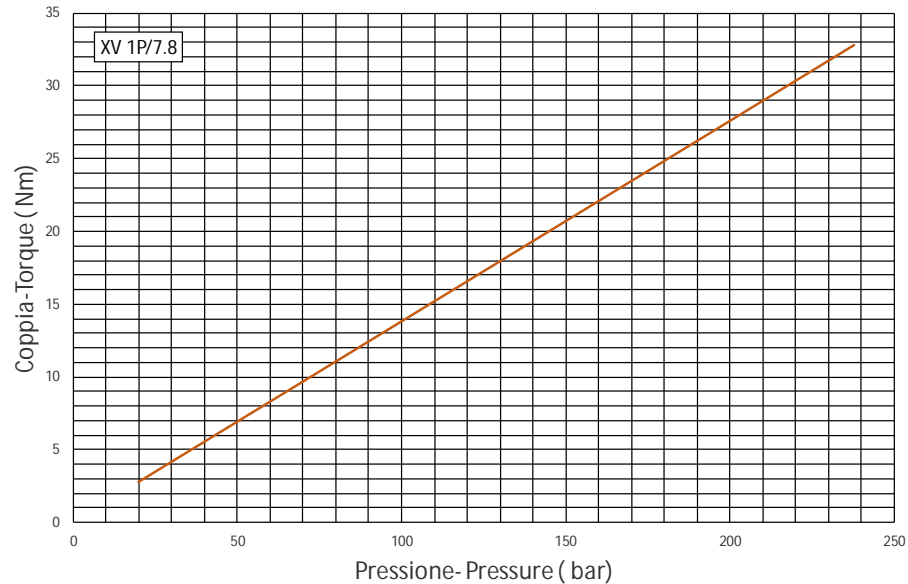

Verso di Rotazione Direction of Rotation	Destra Clockwise	
Cilindrata Displacement	7,54	Cm <sup>3</sup> /rev
Pressione massima continua Max continuous pressure	P1	220 bar
Pressione massima intermittente Max intermittent pressure	P2	238 (1) bar
Pressione massima di picco Max peak pressure	P3	238 (1) bar
Regime Min - Min Rpm	700	Rpm
Regime Max - Max Rpm	5000	Rpm
Pressione massima in aspirazione Max inlet pressure	0,6	bar
Tipo di olio raccomandato Recommended oil type	Olio idraulico a base minerale Mineral-based hydraulic oil HLP HV (DIN 51524)	
Viscosità minima di esercizio Minimum operating viscosity	10	mm <sup>2</sup> /s
Viscosità massima di esercizio Minimum operating viscosity	100	mm <sup>2</sup> /s
Viscosità massima ammissibile all'avvio maximum admissible viscosity at stat-up	1500	mm <sup>2</sup> /s
Viscosità consigliata Raccomanded viscosity	20-100	mm <sup>2</sup> /s
Temperatura ambiente Ambient temperature	-20-60	°C
Temperatura di esercizio del fluido Fluid operating temperature	-15-80	°C
Temperatura di esercizio consigliata del fluido Raccomanded fluid operating temperature	30-50	°C
Filtraggio fluido in ingresso Inlet fluid filtering	30-60	µm
Filtraggio fluido in uscita Outlet fluid filtering	10-25	µm
Guarnizioni Sales Type	NBR	
Depressione massima del fluido in ingresso Max inlet fluid pressure	-0,02-0,08	bar
Impiego di Acqua -Glicol (HF-C) Use of Water-Glicol (HF-C)	Max 1100 rpm	Max 170bar
Coppia serraggio viti Screw torque	T1	M8 - 24,5-29,4 Nm
Coppia Massima Ammissibile sull'albero Admissible shaft torque	T2	32,8 Nm

(1) pressione limitata dalla coppia dell'albero  
limited pressure by shaft torque



VIVOIL OLEODINAMICA VIVOLO s.r.l.  
Società a Socio Unico  
www.vivolo.com  
BUDRIO (BOLOGNA) ITALY  
Tel +39 051.803689 Fax +39 051.800061

**XV1P/7.8 - Ø32 BH /D OUT - CI002**  
Z - Z - IN 3/8"BPS



Disegno:

Data - Emissione  
04/06/20

**7P3444003**