

VIVOIL OLEODINAMICA VIVOLO s.r.l.
Società a Socio Unico
www.vivoil.com
BUDRIO (BOLOGNA) ITALY
Tel +39 051.803689 Fax +39 051.800061

XV1P/3.8 - Ø32 BH /D OUT - CI002
Z - Z - IN 3/8"BPS

Disegno: **7P2544001**
Data - Emissione: 04/06/20

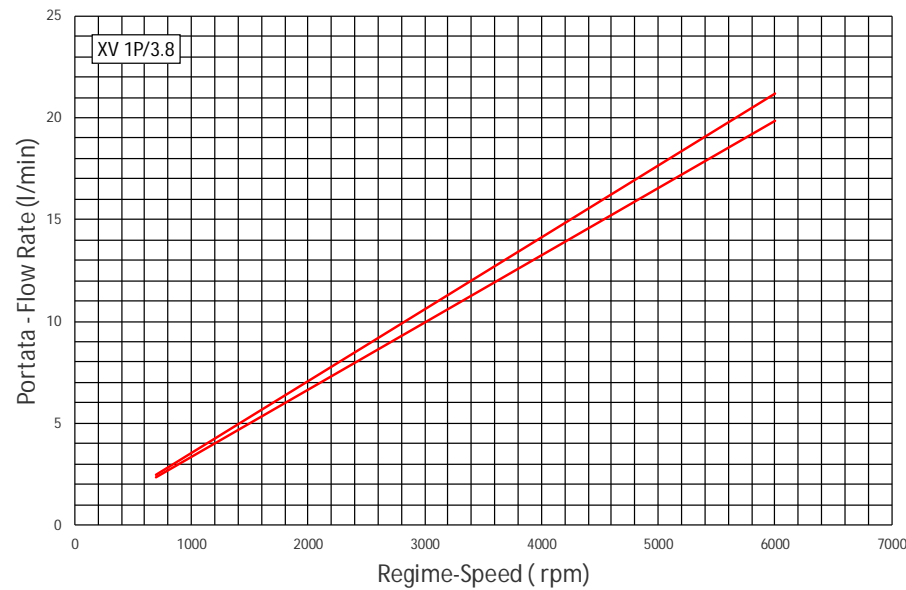
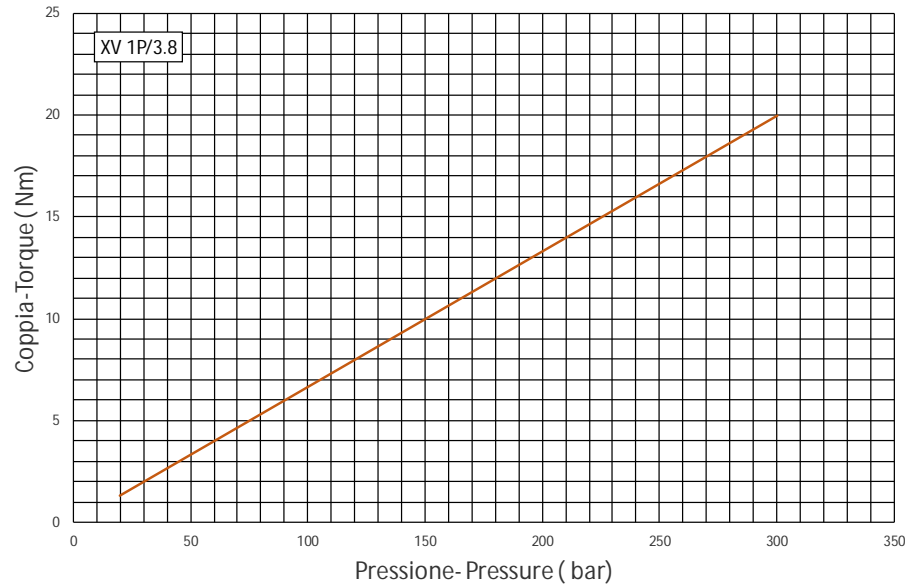
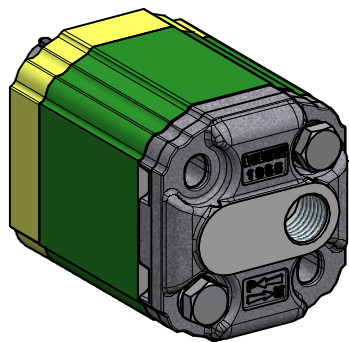
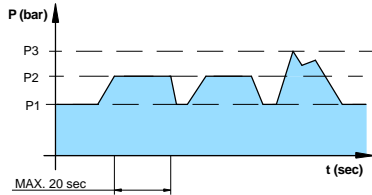
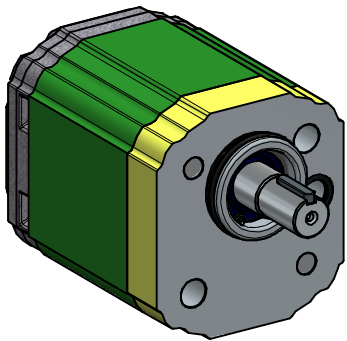

Verso di Rotazione Direction of Rotation	Destra Clockwise	
Cilindrata Displacement	3,64	Cm ³ /rev
Pressione massima continua Max continuous pressure	P1	250 bar
Pressione massima intermittente Max intermittent pressure	P2	280 bar
Pressione massima di picco Max peak pressure	P3	300 bar
Regime Min - Min Rpm	700	Rpm
Regime Max - Max Rpm	6000	Rpm
Pressione massima in aspirazione Max inlet pressure	0,6	bar
Tipo di olio raccomandato Recommended oil type	Olio idraulico a base minerale Mineral-based hydraulic oil HLP HV (DIN 51524)	
Viscosità minima di esercizio Minimum operating viscosity	10	mm ² /s
Viscosità massima di esercizio Minimum operating viscosity	100	mm ² /s
Viscosità massima ammissibile all'avvio maximum admissible viscosity at start-up	1500	mm ² /s
Viscosità consigliata Recommended viscosity	20-100	mm ² /s
Temperatura ambiente Ambient temperature	-20÷60 °C	
Temperatura di esercizio del fluido Fluid operating temperature	-15÷80 °C	
Temperatura di esercizio consigliata del fluido Recommended fluid operating temperature	30÷50 °C	
Filtraggio fluido in ingresso Inlet fluid filtering	30-60	µm
Filtraggio fluido in uscita Outlet fluid filtering	10÷25	µm
Guarnizioni Sales Type	NBR	
Depressione massima del fluido in ingresso Max inlet fluid pressure	-0,02÷0,08 bar	
Impiego di Acqua -Glicol (HF-C) Use of Water-Glycol (HF-C)	Max 1100 rpm	Max 170bar
Coppia serraggio viti Screw torque	T1	M8 - 24,5÷29,4 Nm
Coppia Massima Ammissibile sull'albero Admissible shaft torque	T2	32,8 Nm



VIVOIL OLEODINAMICA VIVOLO s.r.l.
Società a Socio Unico
www.vivoil.com
BUDRIO (BOLOGNA) ITALY
Tel +39 051.803689 Fax +39 051.800061

XV1P/3.8 - Ø32 BH /D OUT - CI002
Z - Z - IN 3/8" BPS



Data - Emissione
04/06/20

Disegno:

7P2544001