

IEC AC Motor  
Frame Size 71/80/90/100

ES Series  
Single Phase

AC  
Motor

**Specifications** - WD series, Single Phase

Model	IEC Frame	Installation method	Rated voltage(v)	Rated output power(w)	Rated current(A)
E03S-2-71-B35-WD-ML	71	B35	220	370	3
E05S-2-71-B35-WD-ML	71	B35	220	550	4
E07S-2-80-B34-WD-MLD	80	B34	220	750	5.3
E11S-2-80-B34-WD-MLD	80	B34	220	1100	6.7
E15S-2-90L-B34-WD-MLD	90L	B34	220	1500	9.7
E22S-2-90L-B34-WD-MLD	90L	B34	220	2200	14.4
E30S-2-100L-B34-WD-MLD	100L	B34	220	3000	18

- 1.Motor duty cycle S1.
- 2.Insulation class F.
- 3.Protection class Ip54.
- 4.Clockwise rotation of the shaft end
- 5.Motor speed 2800 rev / min
- 6.Electronic centrifugal switch.

CE Certification



Outline dimension

Frame Size 71

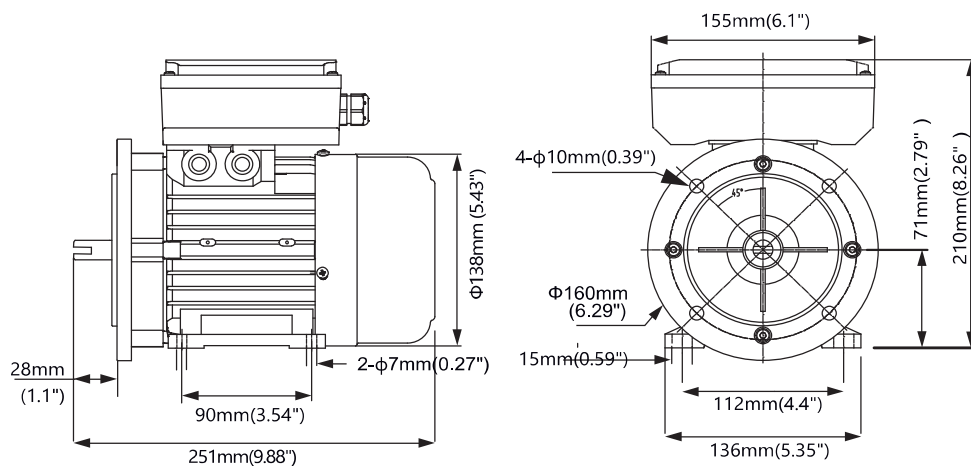

**IEC AC Motor**  
 Frame Size 71/80/90/100

**ES Series**  
 Single Phase

**AC Motor**

**Outline Dimension**

**Frame Size 80**

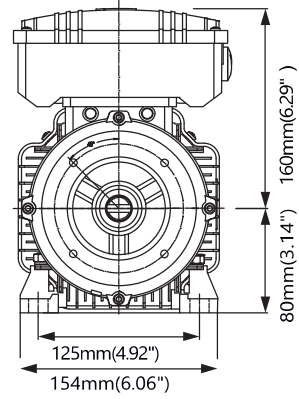
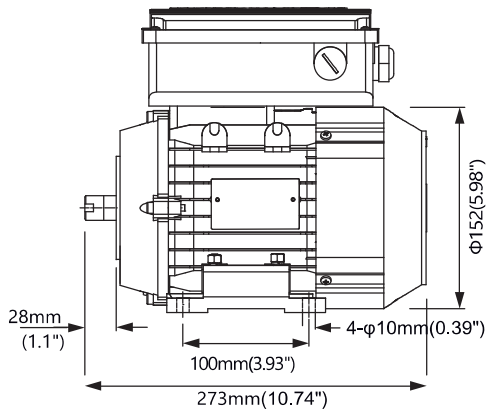

**Frame Size 90L**

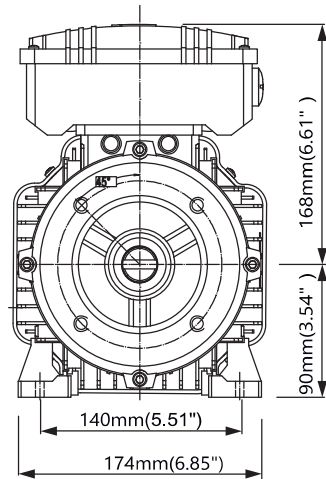
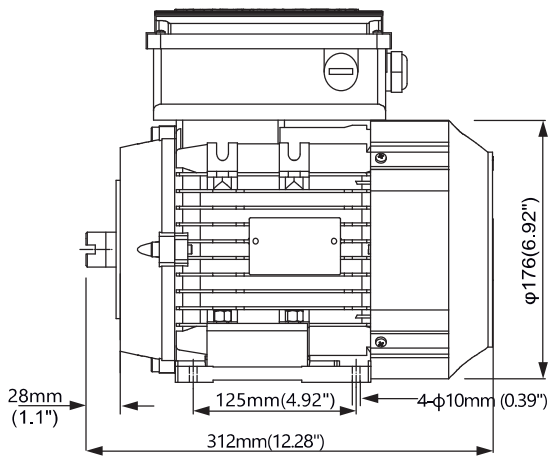

**Frame Size 100L**

